



US009978988B2

(12) **United States Patent**
Yun et al.

(10) **Patent No.:** **US 9,978,988 B2**
(45) **Date of Patent:** **May 22, 2018**

(54) **ORGANIC LIGHT-EMITTING DISPLAY APPARATUS**

(71) Applicant: **SAMSUNG DISPLAY CO., LTD.**,
Yongin-si, Gyeonggi-do (KR)

(72) Inventors: **Wonmin Yun**, Yongin-si (KR);
Eungseok Park, Yongin-si (KR);
Byoungduk Lee, Yongin-si (KR);
Yunah Chung, Yongin-si (KR);
Yoonhyeung Cho, Yongin-si (KR);
Yongchan Ju, Yongin-si (KR)

(73) Assignee: **SAMSUNG DISPLAY CO., LTD.**,
Gyeonggi-Do (KR)

(*) Notice: Subject to any disclaimer, the term of this patent is extended or adjusted under 35 U.S.C. 154(b) by 0 days. days.

(21) Appl. No.: **15/205,668**

(22) Filed: **Jul. 8, 2016**

(65) **Prior Publication Data**
US 2017/0125731 A1 May 4, 2017

(30) **Foreign Application Priority Data**
Nov. 3, 2015 (KR) 10-2015-0153804

(51) **Int. Cl.**
H01L 51/52 (2006.01)
H01L 51/56 (2006.01)

(52) **U.S. Cl.**
CPC **H01L 51/5253** (2013.01); **H01L 51/5259** (2013.01); **H01L 51/56** (2013.01)

(58) **Field of Classification Search**
CPC . H01L 51/52; H01L 51/5253; H01L 51/5259; H01L 51/56
See application file for complete search history.

(56) **References Cited**

U.S. PATENT DOCUMENTS

2011/0127570 A1	6/2011	Um et al.	
2011/0156578 A1	6/2011	Jeon et al.	
2012/0187399 A1*	7/2012	Fukuda	H01L 29/78603 257/43
2014/0361263 A1	12/2014	Kim et al.	
2015/0108442 A1	4/2015	Kim et al.	
2015/0144909 A1*	5/2015	Byun	H01L 51/5253 257/40
2016/0027851 A1*	1/2016	Yanagisawa	H01L 27/3244 257/43
2016/0155979 A1*	6/2016	Yim	H01L 51/5281 257/40

FOREIGN PATENT DOCUMENTS

KR	1020110062156 A	6/2011
KR	1020110077940 A	7/2011
KR	1020140143635 A	12/2014
KR	1020150044723 A	4/2015
KR	1020150074826 A	7/2015

* cited by examiner
Primary Examiner — Phuc Dang
(74) *Attorney, Agent, or Firm* — Cantor Colburn LLP

(57) **ABSTRACT**
An organic light-emitting display apparatus includes a substrate, a pixel electrode on the substrate, a capping layer on the pixel electrode, a second organic layer on the capping layer, a first organic layer between the capping layer and the second organic layer and corresponding to the pixel electrode, and an inorganic layer on the second organic layer.

13 Claims, 7 Drawing Sheets

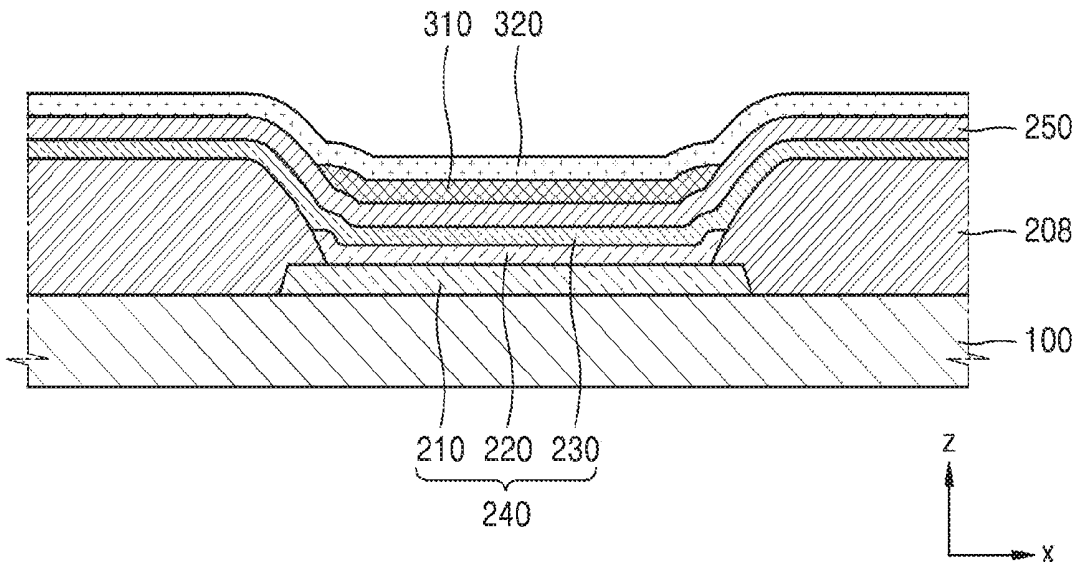

FIG. 1

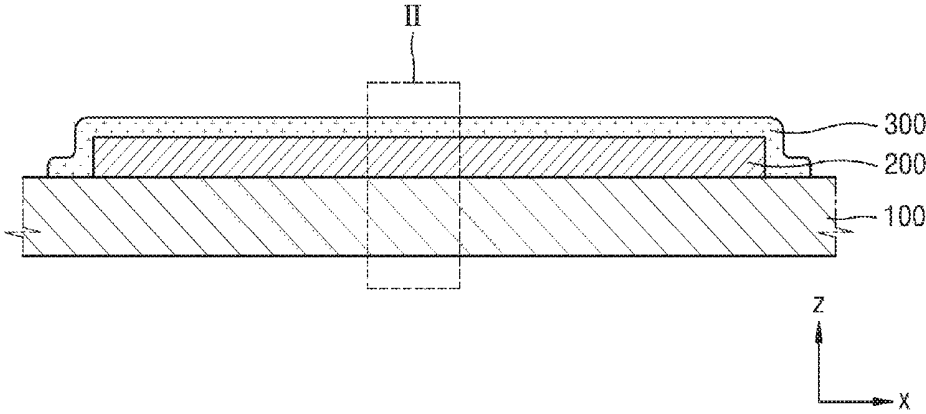

FIG. 2

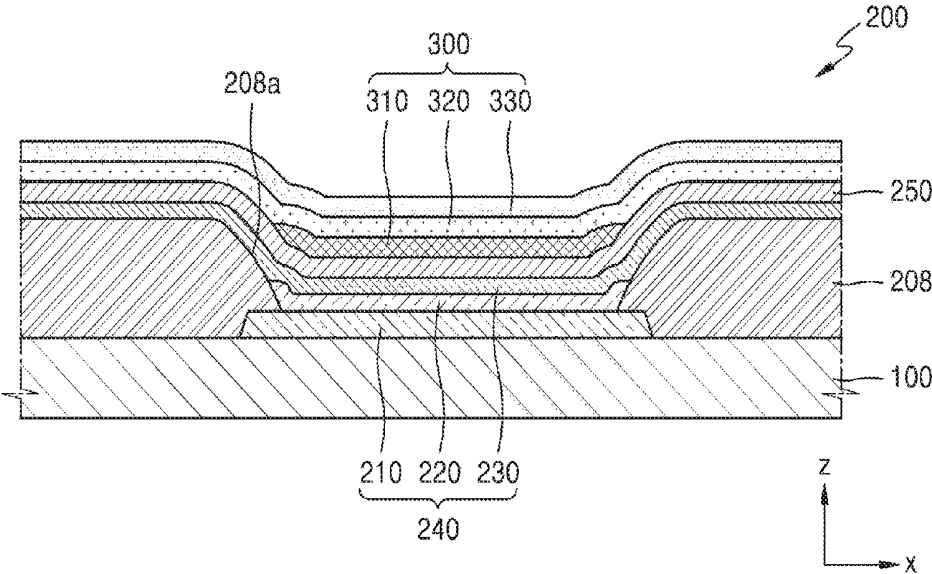

FIG. 3

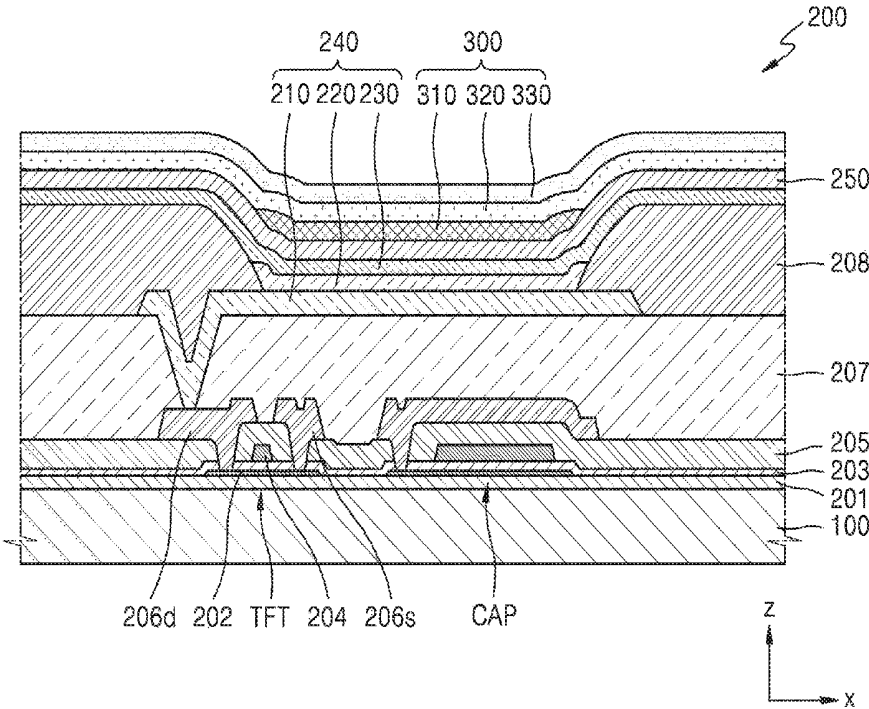

FIG. 4

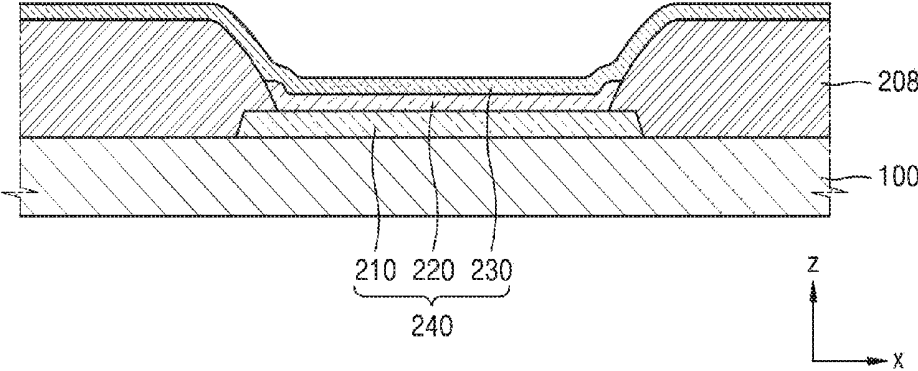

FIG. 5

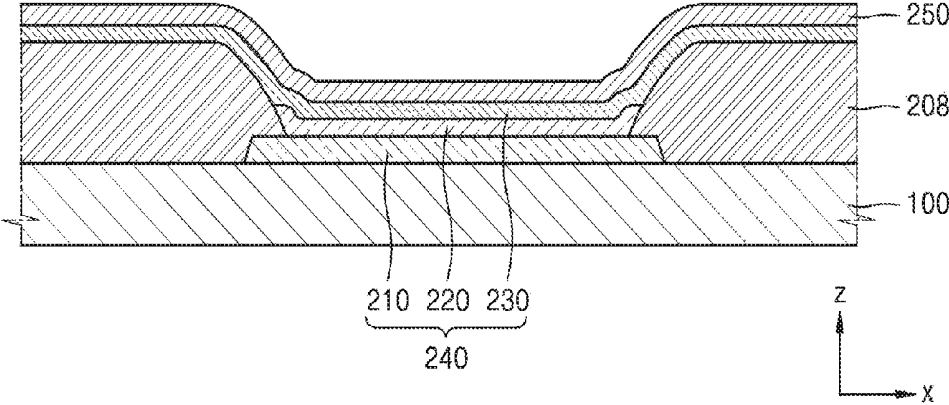

FIG. 6

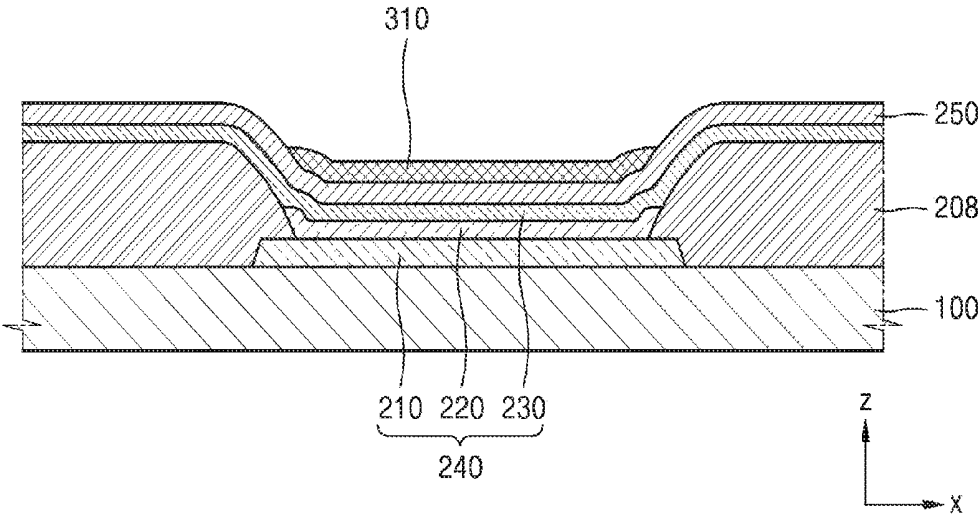
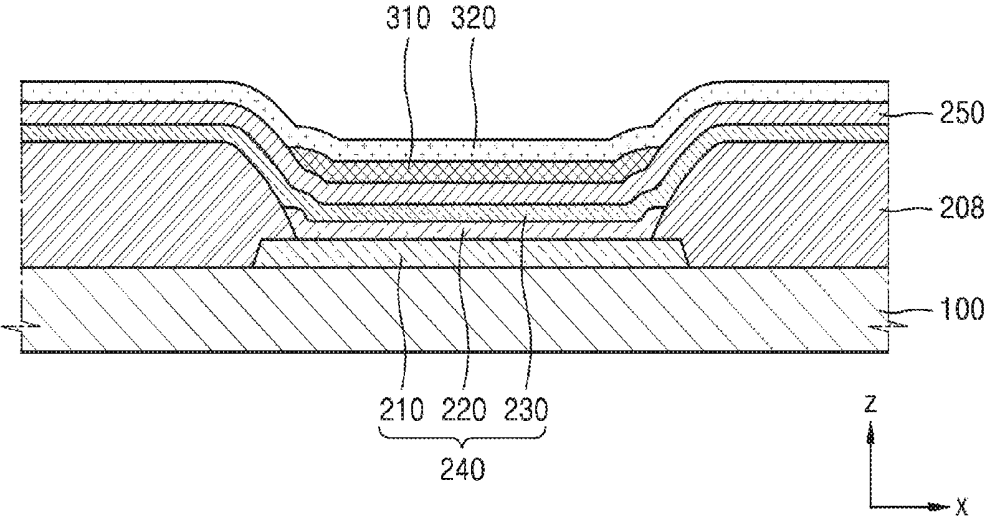

FIG. 7



ORGANIC LIGHT-EMITTING DISPLAY APPARATUS

This application claims priority to Korean Patent Application No. 10-2015-0153804, filed on Nov. 3, 2015, and all the benefits accruing therefrom under 35 U.S.C. § 119, the content of which in its entirety is herein incorporated by reference.

BACKGROUND

1. Field

One or more exemplary embodiments relate to an organic light-emitting display apparatus and a method of manufacturing the same, and more particularly, to an organic light-emitting display apparatus having a simple structure which decreases a thickness thereof and minimizes damage to an organic light-emitting device, and a method of manufacturing the same.

2. Description of the Related Art

Among display apparatuses, an organic light-emitting display apparatus has various advantages such as a wide viewing angle, high contrast, and a high response rate, and thus has drawn much attention as a next-generation display apparatus.

In general, an organic light-emitting display apparatus includes a thin-film transistor and organic light-emitting devices on a substrate, in which the organic light-emitting devices emit light and operate. The organic light-emitting display apparatus may be used as not only a display unit in a small product such as a mobile phone but also a display unit in a large product such as a television.

The organic light-emitting display apparatus includes, as pixels or subpixels, organic light-emitting devices, each of which includes an intermediate layer including an emission layer, is interposed between a pixel electrode and an opposite electrode, and includes a thin-film transistor electrically connected to the organic light-emitting devices and other various elements. The organic light-emitting devices and the other various elements are vulnerable to impurities such as moisture, oxygen, etc. Thus, in order to display a high-quality image, it is important to block moisture and oxygen flowing from the outside to the organic light-emitting devices.

SUMMARY

In an organic light-emitting display apparatus and a method of manufacturing the same according to the related art, when an encapsulation layer is provided to block moisture and oxygen from flowing to an organic light-emitting device from the outside, the organic light-emitting display apparatus has a complicated structure and a thick thickness.

To address the problem and other problems, one or more exemplary embodiments include an organic light-emitting display apparatus and a method of manufacturing the same. However, the one or more of the exemplary embodiments are merely examples and thus the invention is not limited thereto.

Additional exemplary embodiments will be set forth in part in the description which follows and, in part, will be apparent from the description, or may be learned by practice of the presented exemplary embodiments.

According to one or more exemplary embodiments, an organic light-emitting display apparatus includes a substrate, a pixel electrode provided on the substrate, a capping layer provided on the pixel electrode, a second organic layer

provided on the capping layer, a first organic layer interposed between the capping layer and the second organic layer and provided to correspond to the pixel electrode, and an inorganic layer provided on the second organic layer.

In one exemplary embodiment, the first organic layer and the second organic layer may directly contact each other in a surface contact manner.

In one exemplary embodiment, the capping layer and the first organic layer may directly contact each other in a surface contact manner.

In one exemplary embodiment, the capping layer and at least a portion of the second organic layer may directly contact each other in a surface contact manner.

In one exemplary embodiment, the organic light-emitting display apparatus may further include a pixel defining film including an opening for exposing a central portion of the pixel electrode and covering edges of the pixel electrode, and the first organic layer may be provided only in the opening.

In one exemplary embodiment, the organic light-emitting display apparatus may further include an opposite electrode provided on the pixel electrode to face the pixel electrode, and an intermediate layer including an emission layer interposed between the pixel electrode and the opposite electrode. The first organic layer may correspond to the intermediate layer.

In one exemplary embodiment, the first organic layer may include at least one of a vinyl-based resin and fluoro-based resin.

In one exemplary embodiment, the first organic layer may include at least one of a cured material of a first compound and a cured material of a second compound

In one exemplary embodiment, the first compound may include a first main chain, and a first photo-curable functional group bound to both ends of the first main chain.

In one exemplary embodiment, the first main chain may include at least one of C6 to C18 hydrocarbon.

In one exemplary embodiment, the first photo-curable functional group may include a vinyl group.

In one exemplary embodiment, the second compound may include a second main chain, a second photo-curable functional group bound to one side of the second main chain, and a fluoro group.

In one exemplary embodiment, the second main chain may include at least one of C6 to C18 hydrocarbon.

In one exemplary embodiment, the second photo-curable functional group may include an acryl group.

According to one or more exemplary embodiments, a method of manufacturing an organic light-emitting display apparatus includes forming a pixel electrode on a substrate, forming a pixel defining film including an opening for exposing a central portion of the pixel electrode and covering edges of the pixel electrode, forming a capping layer on the pixel electrode, forming a first organic layer on the capping layer in the opening to correspond to the pixel electrode, forming a second organic layer on the first organic layer to cover the first organic layer, and forming an organic layer on the second organic layer.

In one exemplary embodiment, the capping layer and at least a portion of the second organic layer may directly contact each other in a surface contact manner.

In one exemplary embodiment, the first organic layer and the second organic layer may directly contact each other in a surface contact manner.

In one exemplary embodiment, the capping layer and the first organic layer may directly contact each other in a surface contact manner.

In one exemplary embodiment, the first organic layer may include at least one of a vinyl-based resin and fluoro-based resin.

In one exemplary embodiment, the first organic layer may be provided by inkjet printing.

Such general and particular exemplary embodiments may be accomplished according to a system, a method, a computer program, or any combinations thereof.

BRIEF DESCRIPTION OF THE DRAWINGS

These and/or other exemplary embodiments will become apparent and more readily appreciated from the following description of the exemplary embodiments, taken in conjunction with the accompanying drawings, in which:

FIG. 1 is a schematic cross-sectional view of an exemplary embodiment of an organic light-emitting display apparatus according to the invention;

FIGS. 2 and 3 are enlarged cross-sectional views of a portion of FIG. 1, indicated by line II; and

FIGS. 4 to 7 are schematic cross-sectional views illustrating an exemplary embodiment of a process of manufacturing an organic light-emitting display apparatus according to the invention.

DETAILED DESCRIPTION

The invention may be embodied in many different forms and accomplished in various embodiments. Thus, exemplary embodiments are illustrated in the drawings and described in detail herein. The effects and features of the invention and methods of accomplishing them will be apparent from the following embodiments in conjunction with the appended drawings. However, the invention is not limited to the following embodiments and changes may be made in these embodiments.

Hereinafter, exemplary embodiments will be described in detail with reference to the accompanying drawings. In the drawings, the same or corresponding elements are assigned the same reference numerals and are not redundantly described herein.

It will be understood that although the terms 'first', 'second', etc. may be used herein to describe various components, these components should not be limited by these terms. These components are only used to distinguish one component from another. As used herein, the singular forms 'a', 'an', and 'the' are intended to include the plural forms as well, unless the context clearly indicates otherwise.

It will be understood that the terms 'comprise' and/or 'comprising' used herein specify the presence of stated features or components, but do not preclude the presence or addition of one or more other features or components. It will be further understood that when a layer, region, or component is referred to as being 'on' another layer, region, or component, it can be directly or indirectly on the other layer, film, region, plate, or component. That is, for example, intervening layers, regions, or components may be present.

Sizes of elements in the drawings may be exaggerated for convenience of explanation. In other words, since sizes and thicknesses of components in the drawings are arbitrarily illustrated for convenience of explanation, the following embodiments are not limited thereto.

In the following examples, the x-axis, the y-axis and the z-axis are not limited to three axes of the rectangular coordinate system, and may be interpreted in a broader sense. For example, the x-axis, the y-axis, and the z-axis

may be perpendicular to one another, or may represent different directions that are not perpendicular to one another.

As used herein, the term 'and/or' includes any and all combinations of one or more of the associated listed items. Expressions such as 'at least one of,' when preceding a list of elements, modify the entire list of elements and do not modify the individual elements of the list.

Furthermore, relative terms, such as "lower" or "bottom" and "upper" or "top," may be used herein to describe one element's relationship to another element as illustrated in the Figures. It will be understood that relative terms are intended to encompass different orientations of the device in addition to the orientation depicted in the Figures. In an exemplary embodiment, when the device in one of the figures is turned over, elements described as being on the "lower" side of other elements would then be oriented on "upper" sides of the other elements. The exemplary term "lower," can therefore, encompass both an orientation of "lower" and "upper," depending on the particular orientation of the figure. Similarly, when the device in one of the figures is turned over, elements described as "below" or "beneath" other elements would then be oriented "above" the other elements. The exemplary terms "below" or "beneath" can, therefore, encompass both an orientation of above and below.

"About" or "approximately" as used herein is inclusive of the stated value and means within an acceptable range of deviation for the particular value as determined by one of ordinary skill in the art, considering the measurement in question and the error associated with measurement of the particular quantity (i.e., the limitations of the measurement system). For example, "about" can mean within one or more standard deviations, or within $\pm 30\%$, 20%, 10%, 5% of the stated value.

When a certain embodiment may be implemented differently, a specific process order may be performed differently from the described order. In an exemplary embodiment, two consecutively described processes may be performed substantially at the same time or performed in an order opposite to the described order.

FIG. 1 is a schematic cross-sectional view of an organic light-emitting display apparatus according to an exemplary embodiment. FIGS. 2 and 3 are enlarged cross-sectional views of a portion of FIG. 1, indicated by line II.

Referring to FIG. 1, the organic light-emitting display apparatus according to an exemplary embodiment includes a substrate **100**, a display unit **200** on the substrate **100**, and a thin-film encapsulation layer **300** for sealing the display unit **200**.

In an exemplary embodiment, the substrate **100** may include various materials, e.g., a glass material, a metal material, a plasmatic material, etc. In particular, in order to add a flexible feature to the organic light-emitting display apparatus according to an exemplary embodiment, the substrate **100** may include at least one material having high heat resistance, high durability, and a property of bending into a curved surface, including at least one of polyether sulfone ("PES"), polyacrylate ("PA"), polyetherimide ("PEI"), polyethylene naphthalate ("PEN"), polyethylene terephthalate ("PET"), polyphenylene sulfide ("PPS"), polyarylate ("PAR"), polyimide ("PI"), polycarbonate ("PC"), cellulose triacetate, cellulose acetate propionate ("CAP"), and poly(aryleneether sulfone).

The display unit **200** may be provided on the substrate **100**. The display unit **200** may include a plurality of thin-film transistors and an organic light-emitting device **240** electrically connected to the plurality of thin-film transistors

(refer to FIG. 2). In an exemplary embodiment, the display unit **200** may be a liquid crystal display unit or an organic light-emitting display unit, for example. The display unit **200** may include the organic light-emitting device **240** including a pixel electrode **210** which will be described below, and a capping layer **250** provided on the organic light-emitting device **240** (refer to FIG. 2).

The thin-film encapsulation layer **300** may be provided on the display unit **200**. The thin-film encapsulation layer **300** may include at least one first organic layer **310**, a second organic layer **320**, and an inorganic layer **330**. The thin-film encapsulation layer **300** may seal the display unit **200** such that thin-film encapsulation layer **300** covers the display unit **200** and ends of the thin-film encapsulation layer **300** contact the substrate **100**. When the thin-film encapsulation layer **300** seals the display unit **200**, the display unit **200** may be protected from impurities, such as oxygen, moisture, etc., from the outside.

In order to efficiently seal the display unit **200**, the thin-film encapsulation layer **300** may have a multi-layer structure including a plurality of organic layers **310** and **320** (refer to FIG. 2) and a plurality of inorganic layers **330** (refer to FIG. 2). When the thin-film encapsulation layer **300** has the multi-layer structure described above, the whole thickness of the organic light-emitting display apparatus increases and the organic light-emitting display apparatus has a complicated structure which is difficult to manufacture. Thus, the organic light-emitting display apparatus according to an exemplary embodiment includes the thin-film encapsulation layer **300** including the first organic layer **310**, the second organic layer **320**, and the inorganic layer **330**, which are sequentially provided on the display unit **200**.

Referring to FIG. 2, the organic light-emitting display apparatus according to an exemplary embodiment includes the organic light-emitting device **240** on the substrate **100**, the capping layer **250** on the organic light-emitting device **240**, and the thin-film encapsulation layer **300** on the capping layer **250**. The organic light-emitting device **240** may include the pixel electrode **210**, an intermediate layer **220** including an emission layer ("EML"), and an opposite electrode **230**. The thin-film encapsulation layer **300** may include the first organic layer **310**, the second organic layer **320**, and the inorganic layer **330**.

The organic light-emitting device **240** may include the pixel electrode **210**, the intermediate layer **220** including the EML, and the opposite electrode **230**.

As illustrated in FIG. 2, the pixel electrode **210** may be provided on the substrate **100**. In exemplary embodiments, the providing of the pixel electrode **210** may be provided directly on the substrate **100**, or various layers are provided on the substrate **100** and the pixel electrode **210** is provided on the various layers. In an exemplary embodiment, a thin-film transistor may be provided on the substrate **100**, a planarization film may cover the thin-film transistor, and the pixel electrode **210** may be provided on the planarization film, for example. For convenience of explanation, FIG. 2 illustrates the pixel electrode **210** as being located directly on the substrate **100**. This also applies to the following description.

The pixel electrode **210** may be a transparent or semi-transparent electrode or a reflective electrode. When the pixel electrode **210** is a transparent or semi-transparent electrode, the pixel electrode **210** may include, for example, indium tin oxide ("ITO"), indium zinc oxide ("IZO"), Zinc oxide (ZnO), In₂O₃, indium gallium oxide ("IGO"), or aluminum-doped zinc oxide ("AZO"). When the pixel electrode **210** is a reflective electrode, the pixel electrode **210**

may include a reflective film including Ag, Mg, Al, Pt, Pd, Au, Ni, Nd, Ir, Cr, or any combinations thereof, and a layer including ITO, IZO, ZnO, In₂O₃, IGO, or AZO. Exemplary embodiments are not, however, limited thereto and the pixel electrode **210** may be embodied in many different forms. In an exemplary embodiment, the pixel electrode **210** may include other various materials and be a single layer or a multi-layer structure, for example.

A pixel defining film **208** in which an opening **208a** exposing a central portion of the pixel electrode **210** is defined and which covers edges of the pixel electrode **210** may be further provided on the pixel electrode **210**. Although FIG. 2 illustrates that the pixel defining film **208** is provided directly on the substrate **100** to cover the edges of the pixel electrode **210**, exemplary embodiments are not limited thereto. Similar to the pixel electrode **210**, the pixel defining film **208** may be provided directly on the substrate **100** or various layers may be provided on the substrate **100** and the pixel defining film **208** may be located on the various layers. The pixel defining film **208** may define a pixel region through the opening **208a** exposing the central portion of the pixel electrode **210**.

The intermediate layer **220** may be provided on the central portion of the pixel electrode **210**, i.e., the pixel region defined by the pixel defining film **208**. The intermediate layer **220** may include the EML that emits light from an electrical signal. In addition to the EML, the intermediate layer **220** may include a stack structure including at least one among a hole injection layer ("HIL") and a hole transport layer ("HTL") between the EML and the pixel electrode **210**, and an electron transport layer (ETL) and an electron injection layer ("EIL") between the EML and the opposite electrode **230**, etc., for example. The intermediate layer **220** is not, however, limited thereto and may have various structures.

The intermediate layer **220** may include a low molecular weight organic material or a high molecular weight organic material.

When the intermediate layer **220** includes a low molecular weight organic material, an HTL, an HIL, an ETL, an EIL, and the like may be stacked around the emission layer EML. In addition, other various layers may be stacked when necessary. In this case, various organic materials such as copper phthalocyanine (CuPc), N'-Di(naphthalene-1-yl)-N, N'-diphenyl-benzidine ("NPB"), tris-8-hydroxyquinoline aluminum (Alq3), etc. are applicable.

When the intermediate layer **220** includes a high molecular weight organic material, not only the intermediate layer **220** but also an HTL may be included. In an exemplary embodiment, the HTL may include at least one of poly-(2,4)-ethylene-dihydroxy thiophene ("PEDOT"), polyaniline ("PANT"), etc. In this case, organic materials such as a poly-phenylenevinylene ("PPV")-based polymeric organic material, a polyfluorene-based polymeric organic material, etc., are available. In addition, an inorganic material may be provided between the intermediate layer **220**, the pixel electrode **210**, and the opposite electrode **230**.

The HTL, the HIL, the ETL, and the EIL may be unitary over an entire surface of the substrate **100**, and only the EML may be separately provided for each pixel by inkjet printing, for example.

The opposite electrode **230**, which covers the intermediate layer **220** including the EML and faces the pixel electrode **210**, may be provided on the whole surface of the substrate **100**. The opposite electrode **230** may be a transparent or semi-transparent electrode or a reflective electrode,

When the opposite electrode **230** is a transparent or semi-transparent electrode, the opposite electrode **230** may include a layer including a metal having a low work function, e.g., Li, Ca, LiF/Ca, LiF/Al, Al, Ag, Mg, or any combinations thereof, and a transparent or semi-transparent conductive layer including ITO, IZO, ZnO, or In₂O₃. When the opposite electrode **230** is a reflective electrode, the opposite electrode **230** may include a layer including Li, Ca, LiF/Ca, LiF/Al, Al, Ag, Mg, or any combinations thereof. The structure and materials of the opposite electrode **230** are not, however, limited thereto and may be embodied in many different forms.

The capping layer **250** may be further provided on the opposite electrode **230**. Similar to the opposite electrode **230**, the capping layer **250** may be provided on all the surfaces of the substrate **100** and include an organic material. In an exemplary embodiment, the organic material of the capping layer **250** may be a triphenylamine-based compound, for example. In an exemplary embodiment, the organic material of the capping layer **250** may include, for example, at least one of m-MTDATA, TDATA, 2-TNATA, NPB, TPD, β -NPB, Spiro-TPD, spiro-NPB, α -NPB, TAPC, HMTDP, 4,4',4"-tris(N-carbazolyl)triphenylamine ("TCTA"), polyaniline/dodecylbenzenesulfonic acid ("Pani/DBSA"), poly(3,4-ethylenedioxythiophene)/poly(4-styrenesulfonate) ("PEDOT/PSS"), polyaniline/camphor sulfonic acid ("Pani/CSA"), and polyaniline/poly(4-styrenesulfonate) ("PANI/PSS"), but exemplary embodiments are not limited thereto. The capping layer **250** may improve a rate of extracting light emitted from the organic light-emitting device **240** to increase the optical efficiency of the organic light-emitting display apparatus.

The first organic layer **310** may be provided on the capping layer **250**. The capping layer **250** and the first organic layer **310** may direct contact each other in a surface contact manner. The first organic layer **310** may correspond to the pixel electrode **210**. The providing of the first organic layer **310** to correspond to the pixel electrode **210** may be understood that although FIG. 2 illustrates only one pixel electrode **210**, the display unit **200** includes a plurality of pixel electrodes (not shown) spaced apart from each other and a plurality of first organic layers **310** corresponds to the plurality of pixel electrodes in this case. The first organic layer **310** may correspond to the pixel region defined by the pixel defining film **208**, i.e., the intermediate layer **220** including the EML on the central portion of the pixel electrode **210**. In this case, as described above, the intermediate layer **220** may be also understood as the EML provided for each pixel by inkjet printing rather than the HTL, the HIL, the ETL, the EIL, etc. provided on all the surfaces of the substrate **100**. In other words, the first organic layer **310** may be provided only in the opening **208a** of the pixel defining film **208**.

In an exemplary embodiment, the first organic layer **310** may include at least one of vinyl-based resin and fluoro-based resin.

In detail, the first organic layer **310** may include at least one of a cured material of a first compound and a cured material of a second compound. The first compound may include a first main chain and a first photo-curable functional group bound to the first main chain. In this case, the first photo-curable functional group may be bound to both ends of the first main chain. Thus, the first compound may include two or more first photo-curable functional groups. The first photo-curable functional group may include a vinyl group. As described above, the vinyl group may be bound to both

ends of the first main chain. In an exemplary embodiment, the first main chain may include at least one of C6 to C18 hydrocarbon, for example.

The second compound may include a second main chain and a second photo-curable functional group bound to the second main chain. The second compound may include a second main chain and a second photo-curable functional group bound to the second main chain. In this case, the second photo-curable functional group may be bound to one side of the second main chain. The second photo-curable functional group may include an acryl group but is not limited thereto and may include any material having a photo-curing property. The second main chain may include at least one of C6 to C18 hydrocarbon, for example.

The second organic layer **320** may be provided on the first organic layer **310**. The first organic layer **310** and the second organic layer **320** may directly contact each other in the surface contact manner. Similar to the capping layer **250**, the second organic layer **320** may be provided on all the surfaces of the substrate **100**. Thus, the first organic layer **310** may be disposed between the second organic layer **320** and the capping layer **250**. However, in this case, since the first organic layer **310** is provided only in the opening **208a** of the pixel defining film **208** to correspond to the pixel electrode **210** as described above, the capping layer **250** may directly contact at least a portion of the second organic layer **320** in the surface contact manner although the first organic layer **310** is between the second organic layer **320** and the capping layer **250**.

In an exemplary embodiment, the second organic layer **320** may include, for example, at least one of silicon-based resin, acryl-based resin, methacryl-based resin, polyisoprene, vinyl-based resin, epoxy-based resin, urethane-based resin, cellulose-based resin, and perylene-based resin. In detail, examples of the acryl-based resin include butyl acrylate, ethylhexyl acrylate, etc. In detail, examples of the methacryl-based resin include propylene glycol methacrylate, tetra hydroperfuryl methacrylate, etc. Examples of the vinyl-based resin include vinyl acetate, N-vinyl pyrrolidone, etc. Examples of the epoxy-based resin include cycloaliphatic epoxide, epoxy acrylate, vinyl epoxy-based resin, etc. Examples of the urethane-based resin include urethane acrylate, etc. Examples of the cellulose-based resin include cellulose nitrate, etc. However, exemplary embodiments are not limited thereto.

The inorganic layer **330** may be provided on the second organic layer **320**. The inorganic layer **330** may be provided directly on the second organic layer **320**. Similar to the second organic layer **320**, the inorganic layer **330** may be provided on all the surfaces of the substrate **100**. In an exemplary embodiment, the inorganic layer **330** may include, for example, at least one of silicon nitride, aluminum nitride, zirconium nitride, titanium nitride, hafnium nitride, tantalum nitride, silicon oxide, aluminum oxide, titanium oxide, tin oxide, cerium oxide, and silicon oxynitride (SiON).

FIG. 3 illustrates a display unit **200** including a thin-film transistor according to another embodiment. In the display unit **200**, a pixel electrode **210** may be provided directly on a substrate **100** as described above but various layers including a thin-film transistor may be provided on the substrate **100** and the pixel electrode **210** may be provided on the various layers as illustrated in FIG. 3. The structure of the display unit **200** including the thin-film transistor will be described below.

First, a buffer layer **201** including a silicon oxide or a silicon nitride may be provided on the substrate **100** to

planarize a surface of the substrate **100** or to prevent an impurity or the like from penetrating a semiconductor layer **202** of a thin-film transistor TFT. The semiconductor layer **202** may be provided on the buffer layer **201**.

A gate electrode **204** is provided above the semiconductor layer **202**. A source electrode **206s** and a drain electrode **206d** are electrically connected to each other according to a signal supplied to the gate electrode **204**. In an exemplary embodiment, the gate electrode **204** may be provided in a single layer or a multi-layer structure including, for example, at least one among aluminum (Al), platinum (Pt), palladium (Pd), silver (Ag), magnesium (Mg), gold (Au), nickel (Ni), neodymium (Nd), iridium (Ir), chromium (Cr), lithium (Li), calcium (Ca), molybdenum (Mo), titanium (Ti), tungsten (W), and copper (Cu), taking account into an adhesive property between the gate electrode **204** and a layer adjacent thereto, a surface smoothness of a surface of a layer to be stacked thereon, processability, etc.

In this case, in order to secure an insulating property between the semiconductor layer **202** and the gate electrode **204**, a gate insulating film **203** including a silicon oxide and/or a silicon nitride may be disposed between the semiconductor layer **202** and the gate electrode **204**.

An interlayer insulating film **205** may be provided on the gate electrode **204**. The interlayer insulating film **205** may be provided in a single layer or a multi-layer structure including a silicon oxide, a silicon nitride, etc., for example.

The source electrode **206s** and the drain electrode **206d** are provided on the interlayer insulating film **205**. The source electrode **206s** and the drain electrode **206d** are electrically connected to the semiconductor layer **202** via a hole defined in the interlayer insulating film **205** and the gate insulating film **203**. In an exemplary embodiment, the source electrode **206s** and the drain electrode **206d** may be provided in a single layer or a multi-layer structure including, for example, at least one material among aluminum (Al), platinum (Pt), palladium (Pd), silver (Ag), magnesium (Mg), gold (Au), nickel (Ni), neodymium (Nd), iridium (Ir), chromium (Cr), lithium (Li), calcium (Ca), molybdenum (Mo), titanium (Ti), tungsten (W), and copper (Cu), taking account into a conductive property, etc.

Although not shown, a protective film (not shown) may cover the thin-film transistor TFT so as to protect the thin-film transistor TFT having the structure described above. In an exemplary embodiment, the protective film may include an inorganic material, e.g., a silicon oxide, a silicon nitride, a silicon oxynitride, etc.

A planarization film **207** may be provided on the substrate **100**. The planarization film **207** substantially planarizes a top surface of the thin-film transistor TFT when an organic light-emitting device **240** is provided above the thin-film transistor TFT, and protects the thin-film transistor TFT and various elements. In an exemplary embodiment, the planarization film **207** may include, for example, at least one of an acryl-based organic material, benzocyclobutene ("BCB"), etc. In this case, the buffer layer **201**, the gate insulating film **203**, the interlayer insulating film **205**, and the planarization film **207** may be provided on an entire surface of the substrate **100**.

A pixel defining film **208** may be provided above the thin-film transistor TFT. The pixel defining film **208** may be provided on the planarization film **207** and an opening **208a** exposing a central portion of the pixel electrode **210** may be defined in the pixel defining film **208**. The pixel defining film **208** defines a pixel region through the opening **208a**.

The pixel defining film **208** may be, for example, an organic insulating film. Examples of the organic insulating

film may include a acryl-based polymer such as polymethyl methacrylate ("PMMA"), polystyrene ("PS"), a polymer derivative such as a phenol group, an imide-based polymer, an aryl ether-based polymer, an amide-based polymer, a fluoro-based polymer, a p-xylene-based polymer, a vinyl alcohol-based polymer, and any combinations thereof.

The organic light-emitting device **240** may be provided on the pixel defining film **208**. The structures of the organic light-emitting device **240**, the capping layer **250**, and the thin-film encapsulation layer **300** are as described above with reference to FIG. 2 and are thus not redundantly described here.

In an organic light-emitting display apparatus according to an exemplary embodiment, the thin-film encapsulation layer **300** may be simplified to a structure including the first organic layer **310**, the second organic layer **320**, and the inorganic layer **330**. In this case, in order to minimize damage to the organic light-emitting device **240**, caused by a reaction between the capping layer **250** including an organic material and the second organic layer **320**, the first organic layer **310** including a vinyl group or a fluoro group and having low reactivity with the capping layer **250** is disposed between the capping layer **250** and the second organic layer **320** to correspond to the organic light-emitting device **240**.

Although the organic light-emitting display apparatus has been mainly described above, exemplary embodiments are not limited thereto. In an exemplary embodiment, a method of manufacturing an organic light-emitting display apparatus is also within the scope of invention, for example.

FIGS. 4 to 7 are schematic cross-sectional views illustrating a process of manufacturing an organic light-emitting display apparatus according to an exemplary embodiment.

Referring to FIG. 4, first, a pixel electrode **210** may be disposed on a substrate **100**. The forming of the pixel electrode **210** on the substrate **100** includes forming the pixel electrode **210** directly on the substrate **100** or forming various layers on the substrate **100** and forming the pixel electrode **210** on the various layers. In an exemplary embodiment, a thin-film transistor may be disposed on the substrate **100**, a planarization film may cover the thin-film transistor, and the pixel electrode **210** may be disposed on the planarization film, for example. For convenience of explanation, the pixel electrode **210** is illustrated as being disposed directly on the substrate **100**. This also applies to the following description.

The pixel electrode **210** may be a transparent or semi-transparent electrode or a reflective electrode. When the pixel electrode **210** is the transparent or semi-transparent electrode, the pixel electrode **210** may include, for example, ITO, IZO, ZnO, In₂O₃, IGO, or AZO. When the pixel electrode **210** is the reflective electrode, the pixel electrode **210** may include a reflective film including Ag, Mg, Al, Pt, Pd, Au, Ni, Nd, Ir, Cr, or any combinations thereof and a layer including ITO, IZO, ZnO, In₂O₃, IGO, or AZO. Exemplary embodiments are not, however, limited thereto and the pixel electrode **210** may be embodied in many different forms. In an exemplary embodiment, the pixel electrode **210** may include other various materials and be a single layer or a multi-layer structure, for example.

Thereafter, a pixel defining film **208** in which an opening **208a** exposing a central portion of the pixel electrode **210** is defined and which covers edges of the pixel electrode **210** may be disposed on the pixel electrode **210**. Although FIG. 4 illustrates that the pixel defining film **208** is disposed directly on the substrate **100** to cover the edges of the pixel electrode **210**, exemplary embodiments are not limited

thereto. Similar to the pixel electrode **210**, the pixel defining film **208** may be disposed directly on the substrate **100** or various layers may be disposed on the substrate **100** and the pixel defining film **208** may be disposed on the various layers. The pixel defining film **208** may define a pixel region through the opening **208a** exposing the central portion of the pixel electrode **210**.

Then, an intermediate layer **220** may be disposed on the central portion of the pixel electrode **210**, i.e., the pixel region defined by the pixel defining film **208**. The intermediate layer **220** includes an EML which emits light from an electrical signal. In addition to the EML, the intermediate layer **220** may be provided in a single layer or a multi-layer structure by stacking at least one among an HIL and an HTL between the EML and the pixel electrode **210**, an ETL and an EIL between the EML and the opposite electrode **230**, etc. The intermediate layer **220** is not, however, limited thereto and may have any of other various structures.

In this case, the HTL, the HIL, the ETL, and the EIL may be unitary over an entire surface of the substrate **100** and only the EML may be separately provided for each pixel by inkjet printing.

An opposite electrode **230** covering the intermediate layer **220** including the EML and facing the pixel electrode **210** may be provided on all the surfaces of the substrate **100**. The opposite electrode **230** may be a transparent or semi-transparent electrode or a reflective electrode.

In an exemplary embodiment, when the opposite electrode **230** is a transparent or semi-transparent electrode, the opposite electrode **230** may include a layer including a metal having a low work function, i.e., Li, Ca, LiF/Ca, LiF/Al, Al, Ag, Mg, or any combinations thereof and a transparent or semi-transparent conductive layer including ITO, IZO, ZnO, In₂O₃, or the like. When the opposite electrode **230** is the reflective electrode, the opposite electrode **230** may include a layer including Li, Ca, LiF/Ca, LiF/Al, Al, Ag, Mg, or any combinations thereof. However, the structure and material of the opposite electrode **230** are not limited thereto and the opposite electrode **230** may be embodied in many different forms.

Thereafter, referring to FIG. 5, a capping layer **250** may be disposed on the opposite electrode **230**. Similar to the opposite electrode **230**, the capping layer **250** may be disposed on all the surfaces of the substrate **100** and include an organic material. In an exemplary embodiment, the organic material of the capping layer **250** may be a triphenylamine-based compound. In addition, the organic material of the capping layer **250** may include, for example, m-MTDATA, TDATA, 2-TNATA, NPB, TPD, β -NPB, Spiro-TPD, spiro-NPB, α -NPB, TAPC, HMTDP, TCTA, Pani/DBSA, PEDOT/PSS, Pani/CSA, PANI/PSS, or any combinations thereof, but exemplary embodiments are not limited thereto. The capping layer **250** may improve a rate of extracting light emitted from the organic light-emitting device **240** to increase the optical efficiency of the organic light-emitting display apparatus.

Then, referring to FIG. 6, a first organic layer **310** may be disposed on the capping layer **250**. The capping layer **250** and the first organic layer **310** may directly contact each other in the surface contact manner. The first organic layer **310** may correspond to the pixel electrode **210**. The forming of the first organic layer **310** to correspond to the pixel electrode **210** may include forming a plurality of pixel electrodes (not shown) spaced apart from each other and a plurality of first organic layers **310** respectively corresponding to the plurality of pixel electrodes although FIG. 6 illustrates only one pixel electrode **210**. The first organic

layer **310** may correspond to the pixel region defined by the pixel defining film **208**, i.e., the intermediate layer **220** including the EML located on the central portion of the pixel electrode **210**. In this case, as described above, the intermediate layer **220** may be the EML provided for each pixel by inkjet printing rather than the HTL, the HIL, the ETL, the EIL, etc., disposed on all the surfaces of the substrate **100**. In other words, the first organic layer **310** may be located only in the opening **208a** of the pixel defining film **208**.

In an exemplary embodiment, the first organic layer **310** may include at least one of a vinyl-based resin and a fluoro-based resin, for example.

In detail, the first organic layer **310** may include at least one of a cured material of a first compound and a cured material of a second compound. The first compound may include a first main chain and a first photo-curable functional group bound to the first main chain. In this case, the first photo-curable functional group may be bound to both ends of the first main chain. Thus, the first compound may include two or more first photo-curable functional groups. In an exemplary embodiment, the first photo-curable functional group may include a vinyl group, for example. As described above, the vinyl group may be bound to both ends of the first main chain. In an exemplary embodiment, the first main chain may include at least one of C6 to C18 hydrocarbon, for example.

The second compound may include a second main chain and a second photo-curable functional group bound to the second main chain. The second compound may include a second main chain and a second photo-curable functional group bound to the second main chain. In this case, the second photo-curable functional group may be bound to one side of the second main chain. The second photo-curable functional group may include an acryl group but is not limited thereto and may include any material having a photo-curing property. In an exemplary embodiment, the second main chain may include at least one of C6 to C18 hydrocarbon, for example.

Then, referring to FIG. 7, a second organic layer **320** may be disposed on the first organic layer **310**. The first organic layer **310** and the second organic layer **320** may directly contact each other in the surface contact manner. Similar to the capping layer **250**, the second organic layer **320** may be disposed on an entire surface of the substrate **100**. However, in this case, since the first organic layer **310** is provided only in the opening **208a** of the pixel defining film **208** to correspond to the pixel electrode **210** as described above, the capping layer **250** may directly contact at least a portion of the second organic layer **320** in the surface contact manner although the first organic layer **310** is between the second organic layer **320** and the capping layer **250**.

In an exemplary embodiment, the second organic layer **320** may include, for example, at least one of silicon-based resin, acryl-based resin, methacryl-based resin, polyisoprene, vinyl-based resin, epoxy-based resin, urethane-based resin, cellulose-based resin, and perylene-based resin. In detail, examples of the acryl-based resin include butyl acrylate, ethylhexyl acrylate, etc. Examples of the methacryl-based resin include propylene glycol methacrylate, tetrahydrofurfuryl methacrylate, etc. Examples of the vinyl-based resin include vinyl acetate, N-vinyl pyrrolidone, etc. Examples of the epoxy-based resin include cycloaliphatic epoxide, epoxy acrylate, vinyl epoxy-based resin, etc. Examples of the urethane-based resin include urethane acrylate, etc. Examples of the cellulose-based resin include cellulose nitrate, etc. However, exemplary embodiments are not limited thereto.

Thereafter, referring back to FIG. 2, an inorganic layer 330 may be disposed on the second organic layer 320. The inorganic layer 330 may be disposed directly on the second organic layer 320. Similar to the second organic layer 320, the inorganic layer 330 may be disposed on all the surfaces of the substrate 100. In an exemplary embodiment, the inorganic layer 330 may include, for example, at least one of silicon nitride, aluminum nitride, zirconium nitride, titanium nitride, hafnium nitride, tantalum nitride, silicon oxide, aluminum oxide, titanium oxide, tin oxide, cerium oxide, and silicon oxynitride (SiON).

In an organic light-emitting display apparatus provided according to a method of manufacturing an organic light-emitting display apparatus according to an exemplary embodiment, a thin-film encapsulation layer 300 may be simplified to a structure including the first organic layer 310, the second organic layer 320, and the inorganic layer 330. In addition, in this case, in order to minimize damage to the organic light-emitting device 240, caused by a reaction between the capping layer 250 including an organic material and the second organic layer 320, the first organic layer 310 including a vinyl group or a fluoro group and having low reactivity with the capping layer 250 may be disposed between the capping layer 250 and the second organic layer 320 to correspond to the organic light-emitting device 240.

As described above, according to an exemplary embodiment, an organic light-emitting display apparatus having a simple structure to decrease a thickness thereof and minimizing damage to an organic light-emitting device, and a method of manufacturing the same may be realized. However, the scope of the invention is not limited by the effects.

It should be understood that the exemplary embodiments described herein should be considered in a descriptive sense only and not for purposes of limitation. Descriptions of features or exemplary embodiments within each embodiment should typically be considered as available for other similar features or exemplary embodiments in other exemplary embodiments.

While one or more exemplary embodiments have been described with reference to the figures, it will be understood by those of ordinary skill in the art that various changes in form and details may be made therein without departing from the spirit and scope as defined by the following claims.

What is claimed is:

1. An organic light-emitting display apparatus comprising:

a substrate;
a pixel electrode on the substrate;
a capping layer on the pixel electrode;
a second organic layer on the capping layer;
a first organic layer between the capping layer and the second organic layer and corresponding to the pixel electrode; and
an inorganic layer on the second organic layer, wherein the capping layer and at least a portion of the second organic layer directly contact each other.

2. The organic light-emitting display apparatus of claim 1, wherein the first organic layer and the second organic layer directly contact each other in a surface contact manner.

3. The organic light-emitting display apparatus of claim 1, wherein the capping layer and the first organic layer directly contact each other in a surface contact manner.

4. The organic light-emitting display apparatus of claim 1, further comprising a pixel defining film in which an opening exposing a central portion of the pixel electrode and covering edges of the pixel electrode is defined,

wherein the first organic layer is provided only in the opening.

5. The organic light-emitting display apparatus of claim 1, further comprising:

an opposite electrode on the pixel electrode and faces the pixel electrode; and

an intermediate layer between the pixel electrode and the opposite electrode, the intermediate layer including an emission layer,

wherein the first organic layer corresponds to the intermediate layer.

6. The organic light-emitting display apparatus of claim 1, wherein the first organic layer comprises at least one of a vinyl-based resin and fluoro-based resin.

7. An organic light-emitting display apparatus comprising:

a substrate;
a pixel electrode on the substrate;
a capping layer on the pixel electrode;
a second organic layer on the capping layer;
a first organic layer between the capping layer and the second organic layer and corresponding to the pixel electrode; and

an inorganic layer on the second organic layer, wherein the first organic layer comprises at least one of a cured material of a first compound and a cured material of a second compound.

8. The organic light-emitting display apparatus of claim 7, wherein the first compound comprises:

a first main chain; and
a first photo-curable functional group bound to both ends of the first main chain.

9. The organic light-emitting display apparatus of claim 8, wherein the first main chain comprises at least one of C6 to C18 hydrocarbon.

10. The organic light-emitting display apparatus of claim 8, wherein the first photo-curable functional group comprises a vinyl group.

11. The organic light-emitting display apparatus of claim 7, wherein the second compound comprises:

a second main chain;
a second photo-curable functional group bound to one side of the second main chain; and
a fluoro group.

12. The organic light-emitting display apparatus of claim 11, wherein the second main chain comprises at least one of C6 to C18 hydrocarbon.

13. The organic light-emitting display apparatus of claim 11, wherein the second photo-curable functional group comprises an acryl group.

专利名称(译)	有机发光显示装置		
公开(公告)号	US9978988	公开(公告)日	2018-05-22
申请号	US15/205668	申请日	2016-07-08
[标]申请(专利权)人(译)	三星显示有限公司		
申请(专利权)人(译)	三星DISPLAY CO. , LTD.		
当前申请(专利权)人(译)	三星DISPLAY CO. , LTD.		
[标]发明人	YUN WONMIN PARK EUNGSEOK LEE BYOUNGDUK CHUNG YUNAH CHO YOONHYEUNG JU YONGCHAN		
发明人	YUN, WONMIN PARK, EUNGSEOK LEE, BYOUNGDUK CHUNG, YUNAH CHO, YOONHYEUNG JU, YONGCHAN		
IPC分类号	H01L51/52 H01L51/56		
CPC分类号	H01L51/5253 H01L51/56 H01L51/5259 H01L27/3244		
代理机构(译)	康托科尔伯恩LLP		
优先权	1020150153804 2015-11-03 KR		
其他公开文献	US20170125731A1		
外部链接	Espacenet USPTO		

摘要(译)

一种有机发光显示装置，包括基板，基板上的像素电极，像素电极上的覆盖层，覆盖层上的第二有机层，覆盖层和第二有机层之间的第一有机层以及相应的到像素电极，以及第二有机层上的无机层。

